

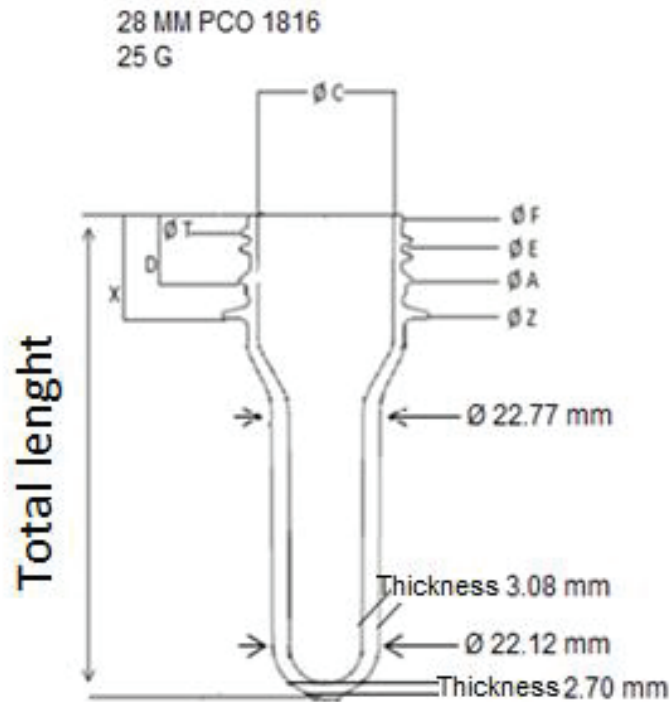

101811

28mm PCO (1816) Clear PET Preform (25 gram)
K.G. International - sales@kgint.com - +1 305 499-9816



QUALITY SPECIFICATION				
Quality variables	Measure units	Minimum	Target	Maximum
Diameter T	mm	27.30	27.43	27.56
Diameter E	mm	24.36	24.51	24.66
Diameter F	mm	24.81	24.94	25.07
Diameter A	mm	27.84	27.97	28.10
Diameter Z	mm	32.62	33.00	33.38
Diameter C	mm	21.61	21.74	21.87
Height D	mm	13.90	14.10	14.30
Height X	mm	20.95	21.20	21.45
Cristalinity	mm		≤ 0.90	
Total lenght	mm	103.70	104.50	105.30
Weight	g	24.70	25.0	25.30
Acetaldehyde	µg/g		≤ 8	
Color	Several			
Reference variable	Neck finish PCO 1816			

APPLICATION AND INTENDED USE
Food contact product
PET injected preforms for use in bottle blowing. This product doesn't have expiry specified time. For carbonated beverage we recommend to use PET preforms at no more than six months later of date off production. For non-carbonated beverage to use PET preforms at no more than ten months later of date off production, matter the weight or volume of the bottle to blow, after this time can be blown, but the window blowing process is reduced, this for optimal storage conditions.
Raw Material
PET Resin: Polyethylene Therefthalate Couloring type: Liquid
The different processes of our production plants meet regulatory requeriments: ISO 9001:2015 y FSSC 22000, to ensure the quality and safety of products supplied. In accordance with FDA CFR 21 § 177.1630 (f) (g).

Packaging

Units per box: 13,968 units
 Plastic bag dimentionis: W 88 x L 97 inches
 Cardboard box (Gaylord) dimentionis: W 3.28 x L 3.94 x H 3.71 ft.
 Wood pallet: W 40 x L 48 inches
 Plastic strip dimentionis: W 0.472 x Thickness 0.028 Inches

Load capacity
 L 48 ft. Standard Land container: 56 boxes.
 L 53 ft. Standard Land Container: 60 boxes.
 L 26 ft. Not standard 26 ft. Land container: 24 boxes.

L 40 ft. HC Standard Sea container: 40 boxes.
 L 20 ft. Standard Sea container: 10 boxes.